

- True RMS @ 1024 Samples/Cycle
- IEC 62053-22 Class 0.2S Compliant
- IEC 61000-4-30 Ed. 3.1 Class A Certified
- IEC 61000-4-15 Flickermeter
- PQ Disturbance Detection
- Disturbance Waveform Recording
- Comprehensive SDR and Energy Logs
- Dual Ethernet and 1xRS-485
- Modbus RTU/TCP, HTTPS, NTP, SMTPS
- Extended Temperature Range
- Extended Warranty
- 5" Color TFT LCD Display @ 800x480
- 4 GB Log Memory
- EN 50160 and IEEE Std 519-2022 Report
- IEC 61000-4-7 Harmonics/Interharmonics
- ½ cycle RMS Recorder
- WF Recording in COMTRADE Format
- 2kHz-150kHz C.E. Measurements
- IEC 61850 Support
- Optional Split-Core Current Probes
- Industrial Grade Components
- Standard Tropicalization

*Designed For Reliability*

*Manufactured To Last*



## Advanced Power Quality Analyzer

### Power Quality Metering

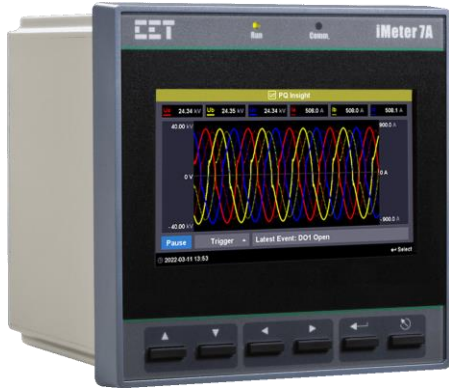

#### PQ Parameters as per IEC 61000-4-30 Ed. 3.1 Class A Certified

- Power Frequency
- Magnitude of the Supply Voltage
- Flicker
- Supply Voltage Interruptions, Dips and Swells
- Supply Voltage Unbalance
- Voltage Harmonics and Interharmonics
- Mains Signalling Voltage on the Supply Voltage
- Rapid Voltage Changes
- Measurement of Over Deviation and Under Deviation Parameters
- Magnitude of Current
- Current Harmonics and Interharmonics
- Current Unbalance
- 2kHz to 150kHz Conducted Emission Measurements

#### Harmonic and Interharmonic Measurements

- K-Factor for Current, Crest Factor for Current and Voltage
- U and I THD, TOHD, TEHD, TIHD, TOIHD, TEIHD and TH (RMS)
- U and I Individual Harmonics (%HD and RMS) from 2<sup>nd</sup> to 63<sup>rd</sup>#
- U and I Individual Interharmonics (%IHD and RMS) from 1<sup>st</sup> to 63<sup>rd</sup>#
- Total Harmonic P, Q, S and PF
- Harmonic P, Q, S and PF from 2<sup>nd</sup> to 63<sup>rd</sup> in RMS
- Fundamental U, I, P, Q, S Phase Angle and Displacement PF
- Harmonic Phase Angle from 2<sup>nd</sup> to 63<sup>rd</sup>
- U and I DC Components

#%HD and %IHD can be configured as % of Fundamental, % of U/I nominal or % of RMS

#### Conducted Emissions in the 2kHz to 150kHz Range

- Real-time amplitude (150/180-cycle) and the Max., Min., Avg. and 95<sup>th</sup> percentile values (in 1-min interval) for Voltage channels with a total of 106 frequency segments (2kHz-150kHz range) and Current channels with a total of 35 frequency segments (2kHz-9kHz range)
- Daily Heat Map display on the Web Interface for the Max., Min., Avg. and 95<sup>th</sup> percentile values

#### Sequence and Unbalance

- Zero, Positive and Negative Sequence Components
- U and I Unbalance based on Zero and Negative Sequence Components

#### Dips, Swells, Interruptions Recording

- Dips, Swells and Interruptions detection @ 10ms (½ cycle at 50Hz)
- Trigger for DO, SOE Log, DR, WFR, DWR, RMSR, iTrigger and Alarm Email
- Configurable DO trigger for the Start or End of a PQ disturbance
- Display of Event specific WFR, DWR and/or RMSR as well as the associated ITIC/SEMI F47 plot on the Front Panel and Web Interface
- ITIC/SEMI F47 Alarm trigger for DO and iTrigger upon the detection of PQ disturbances that are outside of the respective tolerance curves

#### Transients Recording

- Transients capture as short as 20us @ 50Hz or 16.67us @ 60Hz at 1024 samples for sub-cycle disturbances such as capacitor switching and resonance phenomena
- Trigger for DO, SOE Log, WFR, DWR, RMSR, iTrigger and Alarm Email
- Display of Event specific WFR, DWR and/or RMSR on the Front Panel and Web Interface

#### Rapid Voltage Changes (RVC)

- Detection of a quick transition in RMS voltage between two steady-states

#### Inrush Current Monitoring

- Monitoring of the ½ cycle RMS Current and capturing of the Current waveforms associated with events such as motor starting and transformer being energized

#### Disturbance Direction Indicator

- Determine if a PQ Event is located upstream or downstream
- Pinpoint if the cause of the event is external or internal

#### PQ Event Counters

- Dips, Swells, Interruptions, Transients, Rapid Voltage Changes, Inrush Currents, Mains Signalling Voltages and Total PQ Event Counters

The iMeter 7A is one of CET's latest Advanced PQ Analyzer designed for the compliance monitoring market as it offers unsurpassed functionality by combining Class 0.2S Accuracy and advanced PQ Features in a compact DIN 144 form factor with a stunning, high resolution, color TFT LCD display. The iMeter 7A complies with such standards as IEC 62053-22: 2020 Class 0.2S, IEC 61000-4-30 Ed. 3.1 Class A, IEC 61000-4-15, IEC 61000-4-7, EN 50160-2022, IEEE Std 519-2022 and IEC 61850 for Substation Automation. Further, the iMeter 7A offers 4GB memory, dual 10Base-T/100Base-TX Ethernet and one RS-485 ports as well as extensive I/O with 4xDI, 3xDO and optionally 2xSS Pulse Output, 2xAI or 2xRTD. These features likely make the iMeter 7A one of the most Advanced PQ Analyzers for an intelligent Power Quality Monitoring System.

#### Typical Applications

- PQ monitoring at HV, MV and LV Utility Substations
- Data Centers, Semiconductor Fabs, Heavy Industries, Renewable Energy Applications
- 7x24 Automated Manufacturing Facilities
- Mains and critical feeder monitoring
- Dips/Swells/Interruptions, Transients, Flickers & Harmonics Monitoring
- IEC 61850 support for Substation Automation and Smart Grid
- Retrofit applications with optional Class 0.5S Split-Core Current Probes

#### Basic Features

- IEC 62053-22: 2020 Class 0.2S kWh metering with Multi-Tariff TOU
- True RMS @ 1024 samples/cycle sampling
- 4GB on-board log memory
- Industrial-grade, 5" High-Resolution Color TFT LCD @ 800x480
- Device Operating Time (Running Hours)
- Time Sync. via IRIG-B, NTP, IEEE 1588 (PTP) or GPS 1PPS output
- 64 Programmable Setpoints
- Dual 10Base-T/100Base-TX Ethernet and one RS-485 ports

#### Power Quality Features

- IEC 61000-4-30 Ed. 3.1 Class A Certified
- EN 50160-2022 and IEEE Std 519-2022 Reporting
- 2kHz to 150kHz Conducted Emission Measurements
- Dips, Swells, Interruptions, Transients, Rapid Voltage Changes, Inrush Current, Mains Signalling Voltage and Flicker monitoring
- Real-time Waveform Capture (WFC), Waveform Recording (WFR) & Disturbance Waveform Recording (DWR)
- Disturbance Direction Indicator for Dips, Swells and Interruptions
- Statistical Data Recording and ½ cycle RMS Recording
- Waveform Recording in COMTRADE file format

#### Front Panel Display and Web Interface

- True RMS Real-time, Harmonics, Power and Energy Measurements
- Phasor Diagram
- Demands and Multi-Tariff TOU
- Max. & Min. Logs
- Deviation, Sequence & Unbalance
- Real-time WFC of 3-phase U & I @ 128 samples/cycle
- Event Waveforms, RMS Recording and ITIC/SEMI F47 Curves
- Harmonics & Interharmonics Histogram
- Device and SOE Logs, PQ Counters and I/O Status
- Device Configuration and Diagnostics
- Remote access to Front Panel display via Web Interface



### Metering

#### Basic Measurements (1-second update)

- 3-phase U, I, P, Q, S and PF as well as U4, I4, Ung, Frequency and IR

#### High-Speed Measurements

- 3-phase U, I, P, Q, S and PF as well as U4 and I4 @ ½ cycle
- Frequency @ 1 cycle

#### Energy

- Per-phase kWh, kvarh Import/Export/Net/Total and kVAh Total
- Total RMS kWh, kvarh Import/Export/Net/Total and kVAh Total
- Total Fundamental kWh, kvarh Import/Export/Net/Total
- Total Harmonic kWh, kvarh Import/Export/Net/Total
- Total Harmonic kWh, kvarh Import/Export from 2nd to 63rd

#### Demands

- Present and Predicted Demand for 3-phase U, I, I Fund., P, Q, S, PF as well as U4, I4, I4 Fund., Frequency
- Present Demand for 4-phase U & I THD/TOHD/TEHD, 4-phase Current K-Factor, U and I Unbalances as well as Voltage Deviations and Frequency Deviation
- Max./Min. values per Demand Interval
- Maximum Demands for This Month & Last Month (or Since Last Reset & Before Last Reset)
- Demand Synchronization with DI

#### Multi-Tariff TOU capability

- Two independent sets of TOU Schedule
  - Up to 12 Seasons
  - 90 Holidays or Alternate Days and 3 Weekdays
  - 20 Daily Profiles, each with 12 Periods in 15min intervals
  - 8 Tariffs, each providing the following information:
    - kWh/kvarh Import/Export and kVAh
    - P & Q Import/Export Max. Demands
    - Register rollover at 100,000,000,000.000 kWh
- Switching between two TOU schedules manually or according to pre-programmed time
- 12 Historical Logs for Energy and Max. Demand

### Setpoints

#### PQ Setpoints

- Transients, Dips, Swells, Interruptions, ITIC Alarm, SEMI F47 Alarm
- Rapid Voltage Changes, Inrush Current
- Trigger DO, DR, SOE Log, WFR, DWR, RMSR, iTrigger and Alarm Email

#### Motor Start Setpoint

- Monitoring motor startup procedure with recording of Max. Starting Current, Minimum Voltage and Duration
- Trigger DO, SOE Log, WFR, DWR, RMSR, iTrigger and Alarm Email

#### Control Setpoint

- 64 Control Setpoints can be configured with extensive monitoring sources including U, I, P, Q, S, Frequency, Demands, Harmonics, Unbalances, Deviations, Flickers, Phase Reversal/Loss, TC and AI, etc.
- Configurable thresholds and time delays
- Trigger DO, DR, SOE Log, WFR, DWR, RMSR, iTrigger and Alarm Email

#### Digital Input Setpoint

- Provides Control Output Actions in response to changes in DI status
- Trigger DO, DR, SOE Log, WFR, DWR, RMSR, iTrigger and Alarm Email

### Data and Event Recorders

#### Non-Volatile Log Memory

- 4GB on-board Log memory

#### SOE Log

- 1024 FIFO events time-stamped to ±1ms resolution
- Setpoint event, I/O operation, Dip, Swell, Interruption, Transient, Rapid Voltage Change, Inrush Current, Mains Signalling Voltage, Motor Start, iTrigger, etc.
- Record the characteristic data for Setpoint events as well as WFR, DWR, RMSR, ITIC and SEMI F47 Curve for PQ events

#### Device Log

- 1024 FIFO entries time-stamped to ±1ms resolution
- Power On/Off, Setup changes, Time Sync., Device Operations and Self-diagnostics

#### Statistical Data Recorder (SDR)

- 8 SDR Logs of max. 64 parameters each
- Recording of the Max., Min., Avg. and 95<sup>th</sup> percentile values for real-time measurements including U, I, P, Q, S, PF, Freq., Harmonics, Deviations and Unbalances
- Recording Interval from 1 to 60 minutes
- 90 days @ 3-minute, 300 days @ 10-minute, 450-day @ 15-minute
- Downloadable via free software
- Support FIFO or Stop-When-Full mode

#### Data Recorder (DR)

- 8 DR Logs of max. 64 parameters each
- RMS/Fundamental/Harmonic/Interharmonic Measurements, Demands, Deviations, MSV, Unbalances and Flicker
- Configurable Recording Offset and Interval from 1s to 40 days
- Max. Recording Depth @ 65535 records
- Support FIFO or Stop-When-Full mode

#### Max./Min. Recorder (MMR)

- 4 Max./Min. Recorders of 20 parameters each
- RMS/Fundamental/Harmonic/Interharmonic Measurements, Demands, Deviations, Mains Signalling Voltages, Unbalances and Flicker
- Two transfer modes:
  - Manual: Max./Min. Since Last Reset & Before Last Reset
  - Auto: Max./Min. of This Month & Last Month

#### Interval Energy Recorder (IER) and Accumulative Energy Recorder (AER)

- Both IER Log and AER Log support the recording of per-phase and Total RMS kWh, kvarh Import/Export/Total/Net and kVAh Total, Total Fundamental and Total Harmonic kWh, kvarh Import/Export
- Recording Interval from 1 minute to 65535 minutes
- Max. Recording Depth @ 65535 records
- Support FIFO and Stop-When-Full mode

#### Real-Time Waveform Capture (WFC) and Waveform Recorder (WFR)

- Real-time WF Capture @ 128 samples/cycle
- WFR with max. 128 entries
- Simultaneous capture of 4-phase Voltage and Current Inputs
- (Range of Cycles) x Samples/Cycles with programmable pre-fault and post-fault cycles: (40-400) x1024, (40-800) x512, (40-1600) x256, (40-3200) x128
- Scheduled WFR with max. repetition of 10,000 times and programmable schedule from 1 to 65535 min.
- COMTRADE file format, downloadable from the on-board Web Server or FTPS Server

#### Disturbance Waveform Recorder (DWR)

- 128 entries
- Simultaneous recording of all Voltage (U1-U4) and Current (I1-I4) Inputs
  - Initial Fault: 35 cycles @ 512 samples/cycle
  - Extended Fault: Up to 150 cycles @ 16 samples/cycle
  - Steady State: Up to 360s of 1-cycle absolute peak values
  - Post Fault: 15 cycles @ 512 samples/cycle

#### RMS Recorder (RMSR)

- 128 entries
- 16 channels max., selectable U, I, P, Q, S, PF, Frequency, Freq. Deviation
- Recording Interval from 0.5 to 60 cycles
- Recording Width @ 7200 samples per parameter
- Configurable pre-fault samples from 100 to 500
- 72 seconds of ½ cycle RMS recording @ 50Hz or 60 seconds @ 60Hz

#### iTrigger

- Cross trigger DO, SOE Log, WFR, DWR, RMSR and Alarm Email with other iMeter devices within the same local area network (LAN)
- Provides Group ID and MAC Address as the trigger source

#### IEEE Std 519-2022 Report

- 365 Daily Reports for statistical evaluations on Voltage and Current Harmonics based on 99<sup>th</sup> percentile very short time (3 s) values
- 52 Weekly Reports for statistical evaluations on Voltage Harmonics (95<sup>th</sup> percentile) and Current Harmonics (95<sup>th</sup> and 99<sup>th</sup> percentile) short time (10 min) values
- Programmable settings for Report Mode, PCC Voltage, Max. Short Circuit Current, etc.



## Inputs and Outputs

### Digital Input

- Standard 4 or optional 8 channels, volt free dry contact, 24VDC Internal Excitation
- 1000Hz sampling for status monitoring with programmable debounce
- Pulse counting with programmable weight for each channel for collecting WAGES (Water, Air, Gas, Electricity, Steam) information
- Demand Synchronization and Tariff Switching based on DI Status

### Digital Output

- Standard 2 and optional 4 channels Form A Mechanical Relay for general purpose control or alarming
- Optional 2 SS Relays for Energy pulsing applications
- 1 Normally Closed Mechanical Relay for LOP Alarm

### Analog Input (Optional)

- Optional 2xAI, 0/4-20mA DC input with programmable zero and full scales that can be used to measure external transducer signal
- Optional 2xRTD for Temperature Measurements (PT100 Sensor not included)

## Communications

### Ethernet Port (P1, P2)

- Dual 10Base-T/100Base-TX Ethernet Ports with RJ45 connector
- Selectable IP Addressing Mode – DHCP and Static
- White List for Client Access Control
- Protocols supported: Modbus TCP, HTTPS, NTP, SMTPS, SNMP, FTPS, MQTT, IPsec VPN, RSTP and IEC 61850
- Built-in password protected Web Server with multiple user accounts and pre-defined roles for easy data viewing, setup configuration and firmware upgrade
- Simultaneous client connections for 12xModbus TCP and 4xIEC 61850

### RS-485 (P3)

- One optically isolated RS-485 port with Baud Rate from 1.2 to 38.4 kbps
- Support Modbus RTU and Ethernet Gateway

## Time Synchronization

- Battery-backed Real-time clock @ 6ppm ( $\leq 0.5s/day$ )
- Time Sync. with auto-selection among Modbus RTU, NTP, GPS 1PPS, IRIG-B and IEEE 1588 (PTP)

## System Integration

### PecStar® iEMS

- The iMeter 7A is supported by CET's PecStar® iEMS.
- In addition, the iMeter 7A can be easily integrated into other 3<sup>rd</sup> party systems because of its support of multiple communication ports as well as different industry standard protocols such as Modbus and IEC 61850.

### iPQ Explore

- Compact, password protected free software for simultaneous connection with multiple iMeter series Analyzers
- Support configurations for all Setup parameters
- Display of Real-time Measurements, PQ Events and Waveforms
- Export of IER, AER, DR and SDR Logs as well as EN 50160 and IEEE Std 519-2022 Reports

### 3<sup>rd</sup> Party System Integration

- Easy integration into Substation Automation or Utility SCADA systems via Modbus RTU, Modbus TCP or IEC 61850
- The on-board, password protected Web Server provides user-friendly access to its data and supports the configuration for most Setup parameters via a web browser without the use of proprietary software
- The on-board, password protected FTPS Server allows the Excel files for the logged C.E. Measurement data, IEEE Std 519-2022 Daily and Weekly reports and the COMTRADE files for the waveform records to be downloaded without any special software. The downloaded files can be subsequently viewed using software that supports these industry standard file formats.

## Technical Specifications

Voltage Inputs (V1, V2, V3, VN, V4, V4N)	
Standard (Un)	400VLN/690VLL + 20%
Range	5V to 2Un for 400VLN nominal
Overload	2xUn continuous, 4xUn for 1s
Burden	< 0.5VA/per phase
PT Ratio	
Primary	1-1,000,000V
Secondary	1-1,500V
V4 Primary	1-1,000,000V
V4 Secondary	1-1,500V
Measurement Category	CAT III 1000V
Frequency	40Hz-60Hz @ 50Hz, 48Hz-72Hz @ 60Hz
Current Inputs (-I11, I12, -I21, I22, -I31, I32, -I41, I42)	
Standard (In)	5A (Standard), 1A (Optional)
Range	1% to 400% In
Starting Current	0.1% In
Overload	4xIn continuous, 10xIn for 1s
Burden	< 0.5VA/per phase @ 5A < 0.1VA/per phase @ 1A
CT Ratio	
Primary	1-30,000A
Secondary	1-50A
I4 Primary	1-30,000A
I4 Secondary	1-50A
SCCP Options	Split-Core Current Probe Input @ max. 500mV
SCCP-50A-500mV	5A/50A (In/Imax), max. 500mV Output
SCCP-200A-200mV	20A/200A (In/Imax), max. 200mV Output
SCCP-500A-500mV	500A Imax, max. 500mV Output
SCCP-5000-500mV	Selectable 500A/5000A (Imax) Rogowski Coil, max. 500mV Output
SCCT Options	PMC-SCCT-100A-40mA-16-A, $\phi=16mm$ , Class 0.5 PMC-SCCT-200A-40mA-24-A, $\phi=24mm$ , Class 0.5 PMC-SCCT-400A-40mA-35-A, $\phi=35mm$ , Class 0.5 PMC-SCCT-800A-40mA-A, 80x50mm, Class 0.5 PMC-SCCT-1600A-40mA-A, 130x55mm, Class 0.5
SCCTA Option	PMC-SCCT-5A-2mA-16-A, $\phi=16mm$ , Class 1
Power Supply (L/+, N/-)	
Standard	95-250VAC/VDC $\pm 10\%$ , 47-440 Hz
Optional	20-60VDC
Burden	10W
Overvoltage Category	OVC III 300V
Digital Inputs (DIC, DI1, DI2, DI3, DI4, DIC2, DI5, DI6, DI7, DI8)	
Standard	Dry contact, 24VDC internally wetted
Sampling	1000Hz
Hysteresis	1ms minimum
Digital Outputs (DO11, DO12, DO21, DO22, DO31, DO32, DO41, DO42)	
Type	Form A Mechanical Relay
Loading	5A @ 250VAC/30VDC
Alarm Output (Alarm)	
Loading	5A @ 250VAC or 30VDC
Optional Solid State Pulse Outputs (E1+, E1-, E2+, E2-)	
Type	Form A Solid State Relay
Isolation	Optical
Max. Load Voltage	30VDC
Max. Forward Current	100mA
Optional Analog Inputs (AI1+, AI1-, AI2+, AI2-, SH)	
Type	0-20 / 4-20 mA DC
Overload	24 mA maximum
Optional Temperature Inputs (TC11, TC12, TC21, TC22, SH)	
RTD Type	2-Wire PT100 (sensor not included)
Measurement Range	-40°C to +200°C
GPS Input (CLK+, CLK-, SH)	
Type	GPS, IRIG-B
Accuracy	1ms
Terminals Max. Torque	
U & I Inputs	Max.: 3.6N·m / 36.7kgf·cm / 31.8lb-in / M4 Tightening: 1N·m / 10kgf·cm / 8.85lb-in / M4
DI, DO, AI, TC, GPS & RS-485	Max.: 0.39N·m / 4kgf·cm / 3.47lb-in / M2.5 Tightening: 0.25N·m / 2.5kgf·cm / 2.21lb-in / M2.5



**Environmental Conditions**

Operating Temperature	-25°C to 70°C
Storage Temperature	-40°C to 85°C
Humidity	5% to 95% non-condensing
Atmospheric Pressure	70 kPa to 110 kPa
Pollution Degree	2

**Mechanical Characteristics**

Panel Cutout	138x138 mm
Unit Dimensions	144x144x128 mm
IP Rating	52

**Accuracy**

Parameters	Accuracy	Resolution
Voltage (U)	±0.1%	0.001V
I1, I2, I3, I4	5A/1A ±0.1%	0.001A
	SCCT/SCCTA ±0.1% + Error of SCCT	
	SCCPA ±0.1% + Error of SCCP	
P, Q, S	5A/1A ±0.2%	0.001W/ var/VA
	SCCT/SCCTA ±0.5%	
	SCCPA ±0.5%	
kWh, kVAh	5A/1A IEC 62053-22 Class 0.2S	0.1kXh
	SCCT/SCCTA IEC 62053-21 Class 1	
	SCCPA IEC 62053-22 Class 0.5S	
kvarh	5A/1A IEC 62053-24 Class 0.5S	0.1kvarh
	IEC 62053-23 Class 2	
	SCCT/SCCTA IEC 62053-24 Class 1	
	IEC 62053-23 Class 2	
PF	SCCPA IEC 62053-24 Class 1	0.001
	IEC 62053-23 Class 2	
	SCCPA ±0.5%	
Fundamental Phase Angle	5A/1A ±0.2°	0.1°
	SCCT/SCCTA ±0.2° + Phase Error of SCCT	
	SCCPA ±0.2° + Phase Error of SCCP	
Harmonics Phase Angle	5A/1A ±5°	0.1°
	SCCT/SCCTA ±5° + Phase Error of SCCT	
	SCCPA ±5° + Phase Error of SCCP	
Freq., Freq. Deviation	±0.003 Hz	0.001Hz
Harmonics, Interharmonics	IEC 61000-4-7 Class I	0.01%
U Unbalance	±0.1%	0.01%
I Unbalance	±0.5%	0.01%
Pst, Plt	IEC 61000-4-15 Class F1	0.001

**Typical Wiring Diagrams**

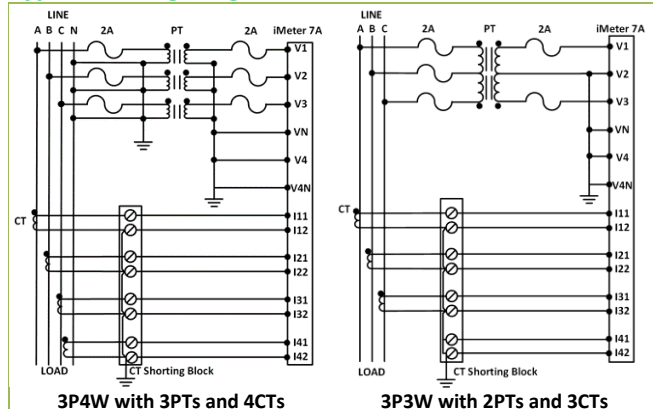

**Terminals Diagram**

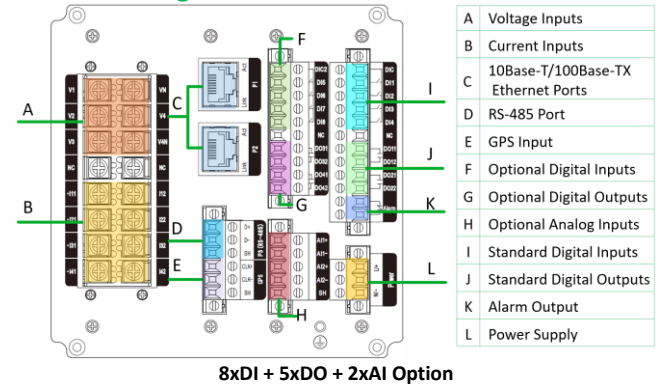

**8xDI + 5xDO + 2xAI Option**

**Dimensions and Installation (Unit: mm)**

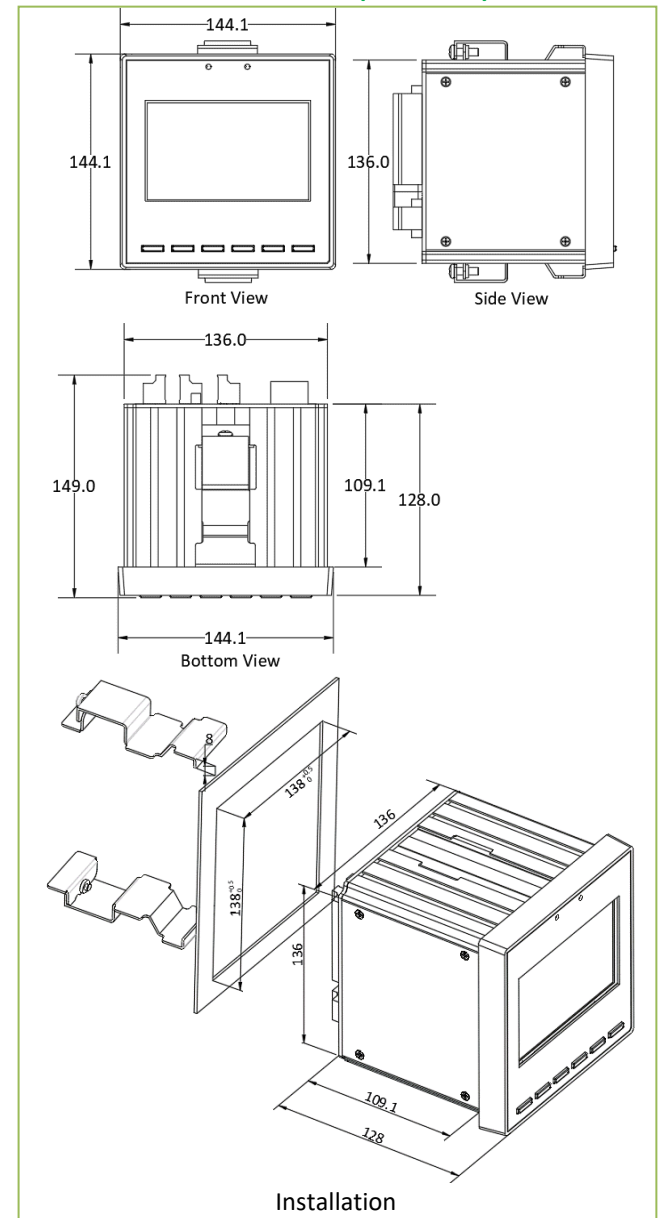

## Front Panel User Interface



17:36  
2022/07/07

Metering Power Quality PQ Insight Events Setup

Real-Time Waveform Latest Event ITC/SEMI F47 WFR

**Main Menu**

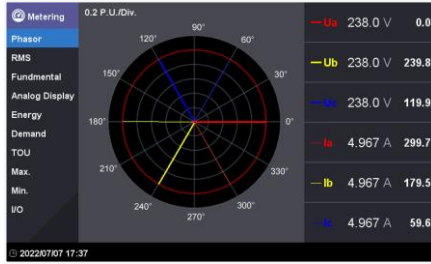

**Phasor Diagram**

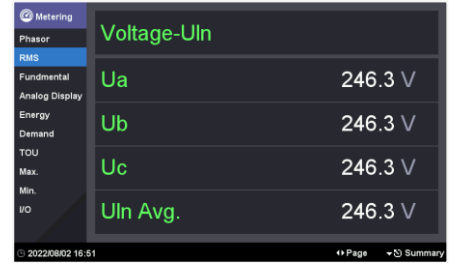

Metering Voltage-Uln

Ua	246.3 V
Ub	246.3 V
Uc	246.3 V
Uln Avg.	246.3 V

**RMS Voltage (Large Font Display)**

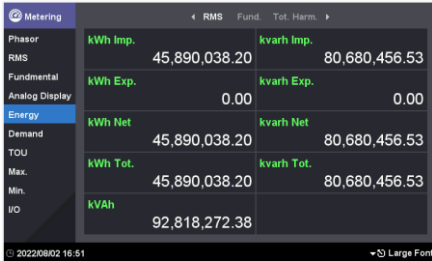

Metering RMS Fund. Tot. Harm.

kWh Imp.	45,890,038.20	kVarh Imp.	80,680,456.53
kWh Exp.	0.00	kVarh Exp.	0.00
kWh Net	45,890,038.20	kVarh Net	80,680,456.53
kWh Tot.	45,890,038.20	kVarh Tot.	80,680,456.53
kVAh	92,818,272.38		

**RMS Energy (Large Font Display)**



Metering Present

P Total Imp.	1.772 kW
P Total Exp.	0.000 W
Q Total Imp.	3.115 kvar
Q Total Exp.	0.000 var

**Present Demand (Large Font Display)**



Metering T1 Energy

kWh Imp.	45,963,860.24
kWh Exp.	0.00
kVarh Imp.	80,810,255.01
kVarh Exp.	0.03
kVAh	92,967,595.44

**TOU Energy (Large Font Display)**



Metering Since: 2022/07/07 11:02:00

Parameter	Max.	Timestamp
P Total	1.837 kW	2022/07/07 17:27:06
Q Total	3.229 kvar	2022/07/07 17:27:06
S Total	3.715 kVA	2022/07/07 17:27:06
PF Total	1.000	2022/07/07 11:02:00
Freq.	50.000 Hz	2022/07/07 17:01:12
Ua	245.0 V	2022/07/07 17:27:06
Ub	245.0 V	2022/07/07 17:27:06
Uc	245.0 V	2022/07/07 17:27:06

**Max. Log**



PQ Harmonics Ua

THD	9.13 %
TOHD	9.05 %
TEHD	1.21 %
Crest Factor	1.38

**Voltage Harmonics (Large Font Display)**



PQ Interharmonics Ua

THID	0.14 %
TOID	0.08 %
TEID	0.11 %

**Voltage Interharmonics (Large Font Display)**



PQ Interharmonics

No.	Segment	Ua	Ub	Uc
01	2.1 kHz	0.000 V	0.000 V	0.000 V
02	2.3 kHz	0.000 V	0.000 V	0.000 V
03	2.5 kHz	0.000 V	0.000 V	0.000 V
04	2.7 kHz	0.000 V	0.000 V	0.000 V
05	2.9 kHz	0.000 V	0.000 V	0.000 V
06	3.1 kHz	0.000 V	0.000 V	0.000 V
07	3.3 kHz	0.000 V	0.000 V	0.000 V
08	3.5 kHz	0.000 V	0.000 V	0.000 V
09	3.7 kHz	0.000 V	0.000 V	0.000 V

**2kHz-150kHz C.E. Measurement**



PQ Sequence & Unbalance

U1	243.3 V	I1	5.077 A
U2	0.287 V	I2	0.006 A
U0	0.289 V	I0	0.006 A
U2 Unbalance	0.12 %	I2 Unbalance	0.12 %
U0 Unbalance	0.12 %	I0 Unbalance	0.12 %

**Sequence & Unbalance**

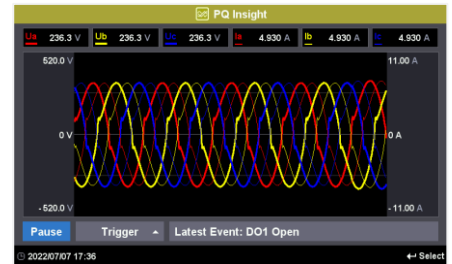

**Real-Time Waveform**

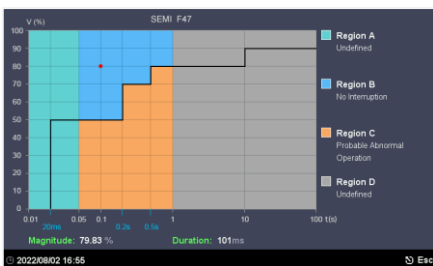

**SEMI F47 Plot**

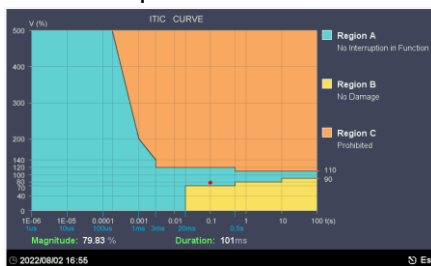

**ITIC Plot**

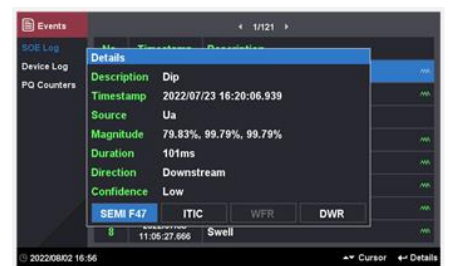

Events SOE Log

Description	Dip
Timestamp	2022/07/23 16:20:06.939
Source	Ua
Magnitude	79.83%, 99.79%, 99.79%
Duration	101ms
Direction	Downstream
Confidence	Low

**SOE Log**

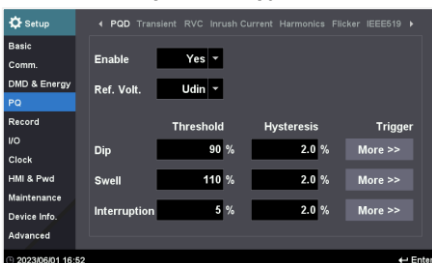

Setup PQD Transient RVC Inrush Current Harmonics Flicker IEC61850-22

Basic Comm. Enable Yes

DMD & Energy Ref. Volt. Udin

Record I/O Threshold 90% Hysteresis 2.0% Trigger More >>

Clock Dip Swell 110% Interruption 5%

**PQ Disturbance Setting**

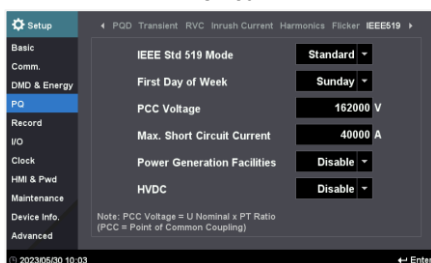

Setup IEEE Std 519 Mode Standard

Basic Comm. IEEE Std 519 Mode Standard

DMD & Energy First Day of Week Sunday

Record I/O PCC Voltage 162000 V Max. Short Circuit Current 40000 A Power Generation Facilities Disable HVDC Disable

**IEEE Std 519 Setting**

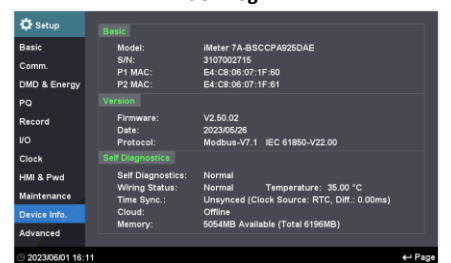

Setup Basic

Basic Comm. Model: iMeter 7A-BSCCPA925DAE  
S/N: 3107022715  
P1 MAC: E4-C8-06-07-1F-50  
P2 MAC: E4-C8-06-07-1F-51

DMD & Energy Version: V2.50.02  
Date: 2023/05/26  
Protocol: Modbus-V7.1 IEC 61850-V22.00

Record I/O Self-Diagnostics: Normal  
HMI & Pwd Wiring Status: Normal Temperature: 35.00 °C  
Maintenance Time Sync.: Unsynced (Clock Source: RTC, Diff.: 0.00ms)  
Device Info. Cloud: Offline  
Advanced Memory: 5054MB Available (Total 6196MB)

**Device Info.**

### Web Interface

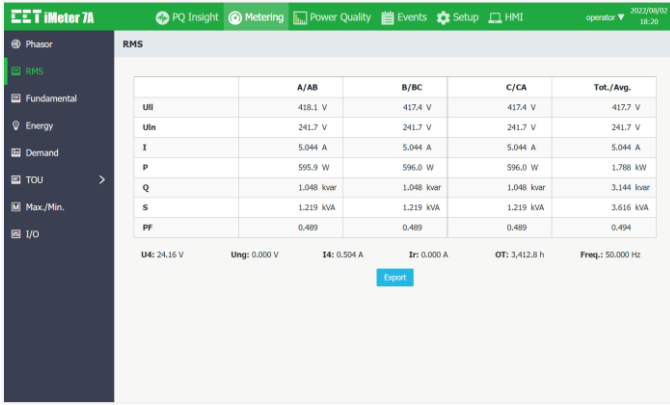

**RMS Metering**

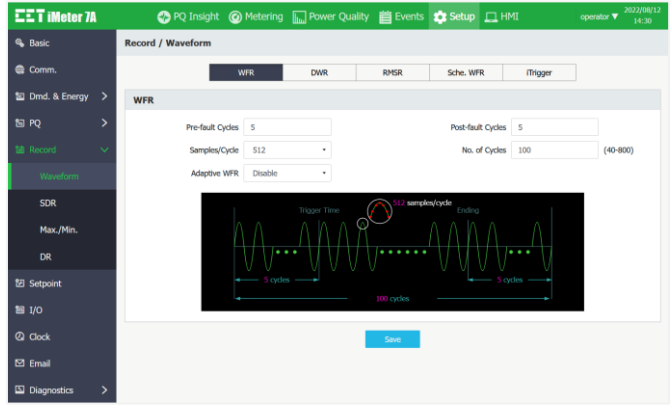

**WFR Setup**

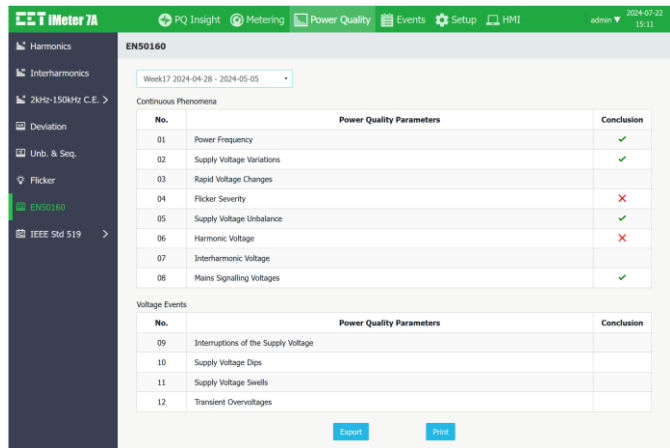

**EN 50160 Report**

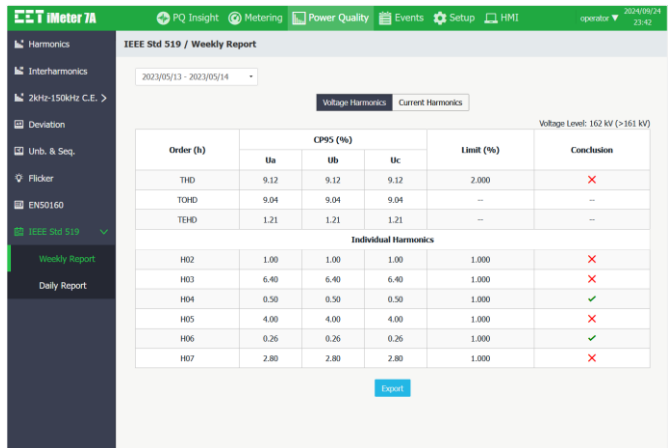

**IEEE Std 519-2020 Weekly Voltage Harmonics Compliance Report**



**RMSR Plot**



**Disturbance Waveform**



**SEMI F47 Plot**



**ITIC Plot**



**Standard of Compliance**

Safety Requirements	
CE LVD 2014 / 35 / EU	EN 61010-1: 2010 + A1: 2019 EN IEC 61010-2-030: 2021 + A11: 2021
cULus Listed	UL 61010-1, Ed.3, Rev 06/06/2023 CAN/CSA C22.2 NO. 61010-1-12, Ed.3, Rev 06/2023
CB Test	IEC 61010-1: 2010, IEC 61010-1: 2010/AMD1: 2016, IEC 61010-2-030: 2017
Electrical Safety in Low Voltage Distribution Systems up to 1000Vac and 1500 Vdc	IEC 61557-12: 2021 (PMD)
Insulation AC Voltage: 2kV @ 1 minute Insulation Resistance: >100MΩ Impulse Voltage: 6kV, 1.2/50μs	IEC 62052-31: 2015 IEC 62053-22: 2003 EN 61010-1: 2010 + A1: 2019
EMC Compatibility	
CE EMC Directive 2014 / 30 / EU (EN IEC 61326: 2021) + ICES-003	
Immunity (EN50082-2)	
Electrostatic Discharge	EN 61000-4-2: 2009
Radiated Fields	EN IEC 61000-4-3: 2020
Fast Transients	EN IEC 61000-4-4: 2019
Surges	EN 61000-4-5: 2014 + A1: 2017
Conducted Disturbances	EN 61000-4-6: 2014 + AC: 2015
Magnetic Fields	EN 61000-4-8: 2010
Voltage Dips and Interruptions	EN IEC 61000-4-11: 2020
Ring Wave	EN 61000-4-12: 2017
Immunity Standard for Industrial Environments	EN IEC 61000-6-2: 2019
Emission (EN50081-2)	
Limits and Methods of Measurement of Electromagnetic Disturbance Characteristics of Industrial, Scientific and Medical (ISM) Radio-Frequency Equipment	EN 55011: 2016 + A1: 2017 + A2: 2021
Electromagnetic Compatibility of Multimedia Equipment - Emission Requirements	EN 55032: 2015 + AC: 2016 + A11: 2020
Limits for Harmonic Current Emissions for Equipment with Rated Current ≤16 A	EN IEC 61000-3-2: 2019 +A1: 2021
Limitation of Voltage Fluctuations and Flicker in Low-Voltage Supply Systems for Equipment with Rated Current ≤16 A	EN 61000-3-3: 2013 + AMD1: 2019 IEC 61000-3-3: 2013 + AMD1: 2019
Emission Standard for Industrial Environments	EN IEC 61000-6-4: 2019
Radiated Emissions Conducted Emissions	FCC 47 CFR Part 15, Subpart B ANSI C63.4: 2014
Limits and Methods of Measurement of Radio Frequency Emissions, as well as Administrative Requirements for ITE, including Digital Apparatus.	ICES-003 Issue 7
Mechanical Tests	
Spring Hammer Test	IEC 62052-31: 2015
Vibration Test	IEC 62052-11: 2020
Shock Test	IEC 62052-11: 2020
Power Quality	
Voltage Characteristics of Electricity supplied by Public Distribution Systems	EN 50160: 2022
General Guide on Harmonic and Interharmonic Measurements and Instrumentation, for Power Supply Systems and Equipment Connected Thereto	IEC 61000-4-7: 2009
Flickermeter - Functional and Design Specifications	IEC 61000-4-15: 2010
Testing and Measurement Techniques - Power Quality Measurement Methods	IEC 61000-4-30: 2021 Ed. 3.1 Class A Certified
Power Quality Measurement in Power Supply Systems - Part 2: Functional Tests and Uncertainty Requirements	IEC 62586-2: 2021 Ed. 2.1

**Ordering Guide**

Version 20260128	
Product Code	Description
iMeter 7A Advanced Power Quality Analyzer	
Basic Feature	
A	IEC 61000-4-30 Ed. 3.1 Class A Certified with 2kHz-9kHz C.E. Measurements
B*	IEC 61000-4-30 Ed. 3.1 Class A Certified with 2kHz-150kHz C.E. Measurements
Input Current	
5	5A
1	1A
SCCT	For use with 100A/200A/400A/800A/1600A to 40mA SCCTs (SCCTs not included)
SCCTA	For use with 5A/2mA SCCT (SCCTs not included)
SCCPA*	SCCP Option for use with CT Clamps with max. 500mV output (SCCPs not included)
Input Voltage	
9	400VLN/690VLL + 20%
Power Supply	
2	95-250VAC/DC ± 10%, 47-440Hz
3*	20-60VDC
System Frequency	
5	50Hz
6	60Hz
I/O	
A	4xDI + 3xDO
B	4xDI + 1xDO + 2xSS Pulse Output
C*	8xDI + 5xDO + 2xAI
D*	8xDI + 5xDO + 2xRTD Input
Communications	
A	2x100BaseT + 1xRS-485
Display Language	
E	English
iMeter 7A - A 5 9 2 5 A A E iMeter 7A-A5925AAE (Standard Model)	

\*Additional charges apply  
 ^ The SCCPA option is compatible with the SCCP models listed in the "SCCP and Accessories" sheet. This option does not come with any Current Clamp. Please refer to the "SCCP and Accessories" sheet for more information and order the desired model and quantity as a separate item.

**CET Electric Technology Inc.**  
 E: [sales@cet-global.com](mailto:sales@cet-global.com)  
 W: [www.cet-global.com](http://www.cet-global.com)

**Your Local Representative**

Revision Date: March 20, 2026